



BUILD BEYOND IMAGINATION





YOUR TRUSTED EQUIPMENT AND ATTACHMENTS SPECIALIST

EIK®, a recognized name that specializes in designing and building high performance amphibious excavators and quality attachments for various makes and models of earth moving equipment. We gain customers' trust with our non compromising attitude, using only high quality materials and components, ensuring that a consistently high level of workmanship is achieved in every piece of attachment produced. Our customers deserve unparalleled investment performance ratio for choosing our products.

"We Build
With Pride, You Use
With Trust."





The ISO 9001:2015 & 14001:2015 certified facility is fully equipped with the latest and greatest equipment, including state-of-art robotic welding machine for booms and buckets. Our goal is to maintain full in-house capability from the product design stage to the final finished goods. We pride ourselves in delivering a high level of workmanship and desirable solutions for our customers.

Products' design are accomplished by utilizing latest Computer Aided Design (CAD) software, simulated via advance Finite Element Analysis (FEA) engineering software tools, ensuring optimum design integrity. All new products prior launching have to meet our internal DEP criteria:

- Designed for Functionality.
- Engineered for Reliability.
- Priced for High ROI
(Return on Investment) for customer.

EIK supports all environmental conservations and is actively innovating new products to help contribute to the many sustainable efforts such as river rehabilitation, creek and canal cleaning. We are in this together to help Mother Nature from global warming and other destructions to its natural ecosystems.



1.0 AMPHIBIOUS EXCAVATOR

The high performance amphibious excavator is powered by our patented 'multi-synchronous hydraulic motor direct drive' system, the pivotal technology that positions us at the forefront of amphibious excavator design. The paradigm shift in how modern amphibious machines are being designed has won the hearts of numerous customers, both new and experienced amphibious excavator users in the industry.

An amphibious excavator/marsh buggy is specifically designed to manoeuvre in marshy, swampy area and soft terrain, and it can also float on water as an added safety feature. It is completely self propelled and can virtually access all terrains, and yet requires minimum supporting transportation and hoisting equipment. When fitted with a long reach front, the machine offers an unparalleled package with unmatched productivity for your investment. Greater versatility can be easily attained when used in conjunction with the wide range of attachments we produce. We have in-house expertise in designing customized attachments to tackle unique challenges where traditional off- the-shelf solutions fail to deliver.



Optional Features:

- Supplementary pontoons can be added on each side to enhance stability.
- Spuds for supplementary pontoons overcome buoyancy in deep water, provide additional stability and enhance operability on water up to 4 meters deep.
- Hydraulic extendable pontoon system offer the flexibility of narrow track width when fully retracted, particularly useful during transportation.

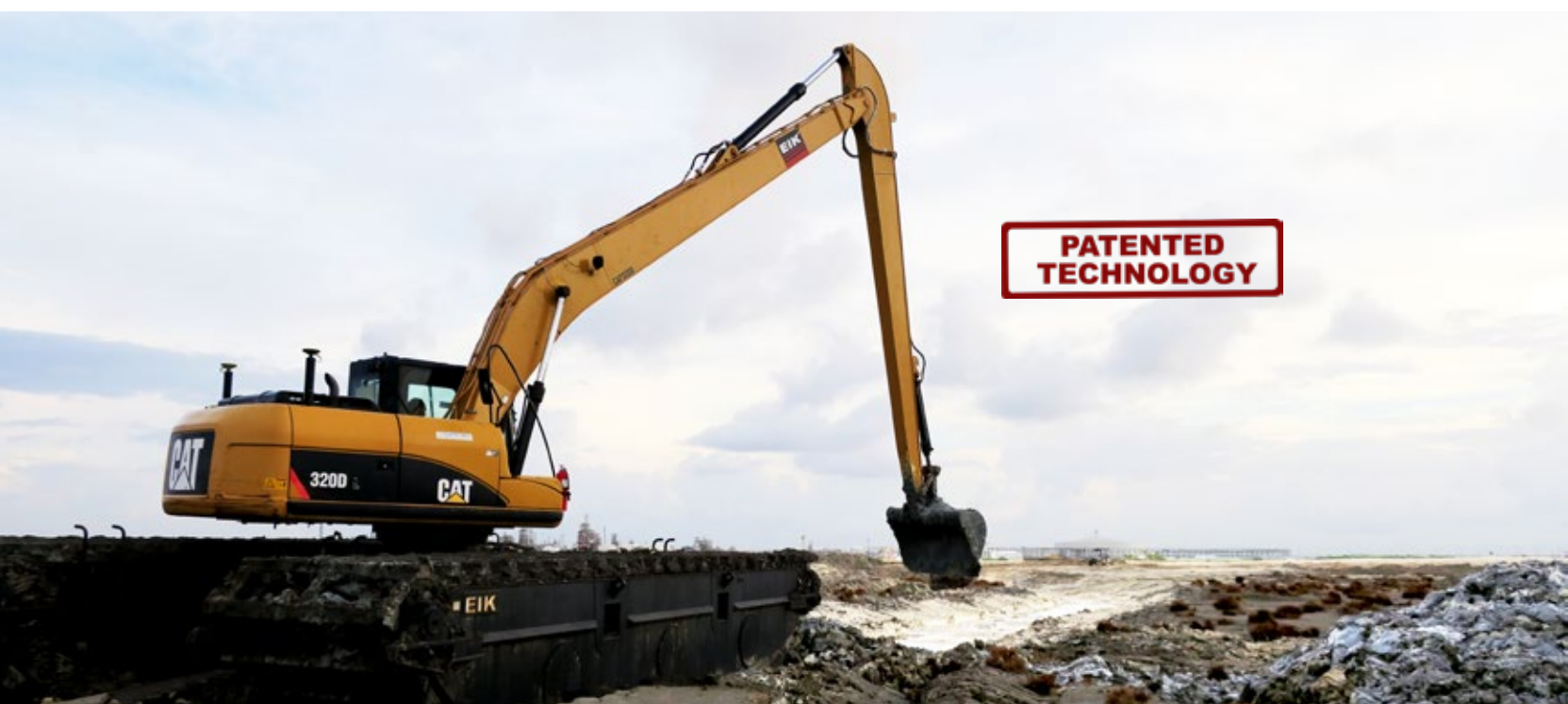

**PATENTED
TECHNOLOGY**



Industry Leading Design and Technology

Drive Motor :

The patented 'multi-synchronous hydraulic motor direct drive' system provides superior tracking capability, making the machine virtually undeterred in any terrain. Multi-motors also offers the advantage of redundancy during unforeseen circumstances.



Hydraulic Extendable pontoons :

An innovative design in the undercarriage system allows each pontoon to retract inward via hydraulic function to achieve a smaller footprint, which is especially useful during land transportation on a low-bed trailer. When extended outwardly, it provides the extra stability needed at work.

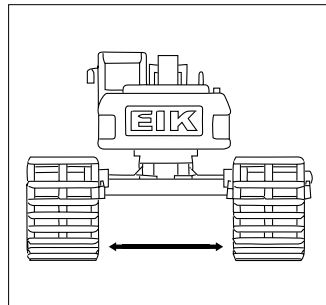

Fully extended

Track Chain :

One of the most critical components of the undercarriage system, is its entirely in-house design and manufacture to ensure proper quality control. One of the criterion of a good design is that the track chain has to perform reliably under various working conditions.

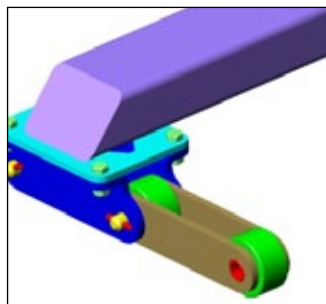

Applications

- Maintenance and cleaning of waterways, lakes, shorelines, ponds, etc.
- Erosion control and prevention.
- Cleaning of tailing dam in mining operation.
- Deepening of waterways and river deltas.
- Maintenance and repair of natural environment.
- Flood protection and flood maintenance works.
- Landscape building and protection.
- Accessing difficult strands of water/soft terrain.
- Swamp and wetland construction.
- Road building through wetlands.

Features

- Patented multi-synchronous hydraulic motor direct drive system.
- Extendable and retractor pontoon system.
- 2 bulkheads per pontoon, hermetically sealed.
- Service manholes on each pontoon for easy maintenance and field servicing.
- Heavy duty track chain system, laser trimmed to extreme precision.
- Hardened rollers and bushings for extended operation life.
- Bolt-on sprocket system for perfect track pitch alignment.
- Modular design for easy transportation.

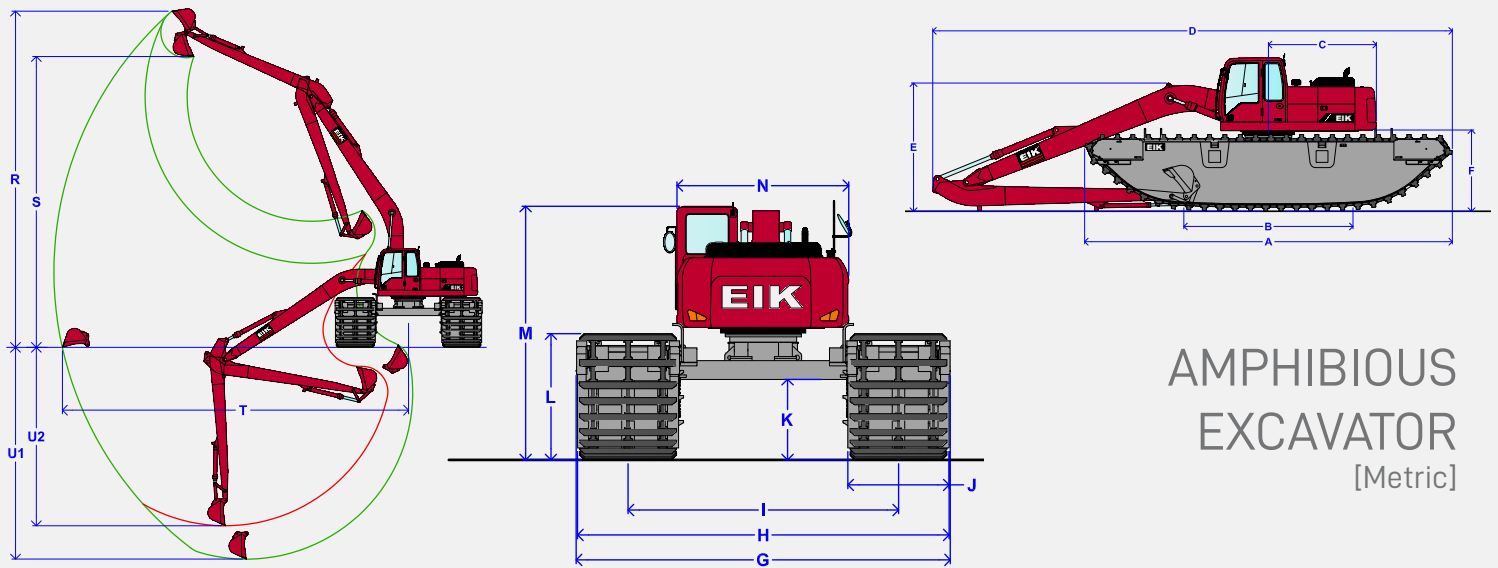

AMPHIBIOUS EXCAVATOR

[Metric]

Dim (m)	Description	Amphibious Undercarriage Models								
		AM60	AM80	AM140	AM200	AM250	AM300	AM350	AM400	AM450
		For 3.5-4.5 ton class excavator	For 7-8 ton class excavator	For 12-14 ton class excavator	For 20-23 ton class excavator	For 24-27 ton class excavator	For 28-30 ton class excavator	For 33-38 ton class excavator	For 39-43 ton class excavator	For 44-48 ton class excavator
A	Max. Track Length	5.56	6.95	9.29	9.63	9.63	10.84	11.84	11.75	11.76
B	Track Length On Ground	2.75	3.20	4.30	4.50	4.50	5.20	5.70	6.00	6.00
C	Rear Upper Structure Length	0.85	1.75	2.13	2.85	3.00	3.19	3.50	3.50	3.56
D	Overall Length	7.90	9.25	12.24	13.55	14.41	15.55	16.59	17.20	18.00
E	Height of Boom	2.40	2.90	2.95	3.47	3.55	4.10	4.12	4.28	4.30
F	Counterweight Clearance	1.52	1.73	1.84	2.17	2.20	2.35	2.35	2.40	2.40
G	Overall Width, min/max (outwardly extendable)	2.78/3.48	3.39/4.19	4.02/5.12	4.50/5.98	5.20 / 6.64	5.94/6.94	6.00/7.00	6.00/7.00	6.43/7.43
H	Undercarriage Width, min/max	2.75/3.45	3.36/4.16	3.94/5.04	4.47/5.95	5.17 / 6.61	5.91 / 6.91	5.97 / 6.97	5.97 / 6.97	6.40 / 7.40
I	Track Gauge, min/max	1.75/2.45	2.06/2.86	2.49/3.59	2.85/4.33	3.25 / 4.69	3.99 / 4.99	4.02 / 5.02	4.02 / 5.02	4.25 / 5.25
J	Track Cleat Width	1.00	1.30	1.45	1.62	1.92	1.92	1.95	1.95	2.15
K	Min. Ground Clearance	1.01	1.15	1.12	1.30	1.30	1.29	1.13	1.16	1.10
L	Track Height	1.46	1.65	1.69	2.03	2.03	2.03	2.03	2.19	2.19
M	Overall Cab Height	3.46	3.65	3.77	4.08	4.12	4.27	4.30	4.30	4.36
N	Upper Structure Overall Width	1.50	2.26	2.45	2.54	2.85	2.96	2.99	3.09	3.53
R	Max. Cutting Height	6.50	7.95	11.40	12.40	13.70	14.60	15.30	15.20	16.30
S	Max. Loading Height	5.20	6.30	9.30	10.50	11.40	12.10	12.80	12.70	13.80
T	Recommended Outreach	7.00	8.00	12.00	14.00	15.00	16.00	17.00	18.00	20.00
U1	Max. Digging Depth from Front	3.70	3.80	7.30	8.90	9.40	9.90	11.00	12.50	13.90
U2	Max. Digging Depth from Side	3.50	3.40	6.50	7.20	7.20	8.50	9.60	10.40	11.30
	Bucket Capacity (m ³)	0.13	0.25	0.40	0.50	0.70	0.80	0.90	1.10	1.10

* The above specifications are for reference only, actual working range may vary from machine models.

** For the benefit of continuous product improvement, specifications are subjected to change without prior notice.

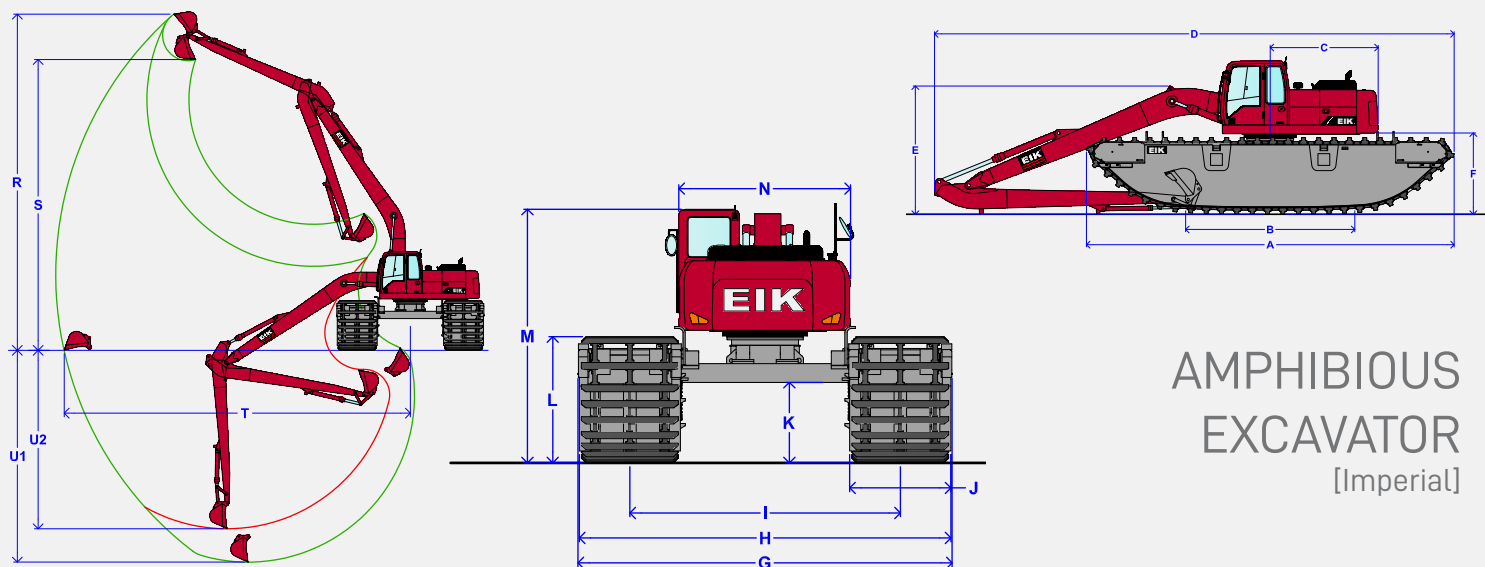

AMPHIBIOUS EXCAVATOR

[Imperial]

Dim (ft & in)	Description	Amphibious Undercarriage Models								
		AM60	AM80	AM140	AM200	AM250	AM300	AM350	AM400	AM450
		For 7,700 - 9,900 lbs excavator	For 15,400 -17,600 lbs excavator	For 26,400 -30,800 lbs excavator	For 44,000 -50,600 lbs excavator	For 52,800 -59,400 lbs excavator	For 61,600 -66,000 lbs excavator	For 72,600- 83,600 lbs excavator	For 85,800 -94,600 lbs excavator	For 96,800 -105,600 lbs excavator
A	Max. Track Length	18' 3"	22' 10"	30' 6"	31' 7"	31' 7"	35' 7"	38' 10"	38' 7"	38' 7"
B	Track Length On Ground	9' 0"	10' 6"	14' 1"	14' 9"	14' 9"	17' 1"	18' 8"	19' 8"	19' 8"
C	Rear Upper Structure Length	2' 9"	5' 9"	7'	9' 4"	9' 10"	10' 6"	11' 6"	11' 6"	11' 8"
D	Overall Length	25' 11"	30' 4"	40' 2"	44' 5"	47' 3"	51'	54' 5"	56' 5"	59' 1"
E	Height of Boom	7' 10"	9' 6"	9' 8"	11' 5"	11' 8"	13' 5"	13' 6"	14' 1"	14' 1"
F	Counterweight Clearance	5'	5' 8"	6'	7' 1"	7' 3"	7' 9"	7' 9"	7' 10"	7' 10"
G	Overall Width, min/max (outwardly extendable)	9' 1" / 11' 5"	11' 1" / 13' 9"	13' 2" / 16' 10"	14' 9" / 19' 7"	17' 1" / 21' 9"	19' 6" / 22' 9"	19' 8" / 23'	19' 5" / 23"	21' 1" / 24' 5"
H	Undercarriage Width, min/max	9' / 11' 4"	11' / 13' 8"	12' 11" / 16' 6"	14' 8" / 19' 6"	17' / 21' 8"	19' 5" / 22' 8"	19' / 22' 3"	19' / 22' 3"	21' / 24' 3"
I	Track Gauge, min/max	5' 9" / 8'	6' 9" / 9' 5"	8' 2" / 11' 9"	9' 4" / 14' 2"	10' 8" / 15' 5"	13' 1" / 16' 4"	19' / 22' 3"	19' / 22' 3"	13' 11" / 17' 3"
J	Track Cleat Width	3' 3"	4' 3"	4' 9"	5' 4"	6' 4"	6' 4"	6' 5"	6' 5"	7' 1"
K	Min. Ground Clearance	3' 4"	3' 9"	3' 8"	4' 3"	4' 3"	4' 3"	3' 8"	3' 10"	3' 7"
L	Track Height	4' 10"	5' 5"	5' 7"	6' 8"	6' 8"	6' 8"	6' 8"	7' 2"	7' 2"
M	Overall Cab Height	11' 4"	12'	12' 4"	13' 5"	13' 6"	14'	14' 1"	14' 1"	14' 4"
N	Upper Structure Overall Width	4' 11"	7' 5"	8'	8' 4"	9' 4"	9' 9"	9' 10"	10' 2"	11' 7"
R	Max. Cutting Height	21' 4"	26' 1"	37' 5"	40' 8"	44' 11"	47' 11"	50' 2"	49' 10"	53' 6"
S	Max. Loading Height	17' 1"	20' 8"	30' 6"	34' 5"	37' 5"	39' 8"	42'	41' 8"	45' 3"
T	Recommended Outreach	23'	26' 3"	39' 4"	45' 11"	49' 3"	52' 6"	55' 9"	59' 1"	65' 7"
U1	Max. Digging Depth from Front	12' 2"	12' 6"	23' 11"	29' 2"	30' 10"	32' 6"	36' 1"	41'	45' 7"
U2	Max. Digging Depth from Side	11' 6"	11' 2"	21' 4"	23' 7"	23' 7"	27' 11"	31' 6"	34' 1"	37' 1"
	Bucket Capacity (yd ³)	0.17	0.33	0.52	0.65	0.92	1.05	1.18	1.44	1.44

* The above specifications are for reference only, actual working range may vary from machine models.

** For the benefit of continuous product improvement, specifications are subjected to change without prior notice.



With our expertise in designing and manufacturing long reach booms, you can now maximize your ROI (Return on Investment) on your existing fleet of excavators. Hundreds of customers have realized the value of long reach attachments where standard booms fail to get the necessary job done, saving valuable cost and time, and maximizing their bottom line. We supply long reach front packages for a wide range of excavator models, ranging from 10 - 250 metric tons (22,000 - 550,000 lbs) operating weight.

We invest heavily in the latest high-tech equipment to stay abreast with the industry. Our facilities are equipped with sophisticated robotic welding machine and CNC line-bore machine. The boom and arm, being critical components of an excavator, require tight tolerance and precision. They are processed with these state-of-the-art machineries to ensure highest attainable quality for every piece we produce. Every time!

Long reach excavators work in the harshest conditions you can imagine. Our ultimate goal is to extend the dependable service life of the product. Product design simulated via advance Finite Element Analysis (FEA) tools. The use of high strength steel increases the product reliability and longevity, and in turn generating higher ROI for customers.

Applications

- Marine and river dredging either on land or on barge.
- Breakwater construction.
- Basement and deep foundation excavation.
- Construction of ditches, levees and pond maintenance.
- Tailing dam maintenance in mining operation

Features

- Use of high strength steel for increased reliability.
- Use of OEM grade bucket cylinder, easy access to spares globally.
- Robotically welded for superior workmanship and consistency.



3-PIECE SUPER LONG FRONT



A 3-piece super long front undeniably triumphs over a traditional 2-piece boom in terms of articulation and versatility. Its advantages include increasing proportionally as the demand on the front end reach increases. The front attachment on a 3-piece long front can access areas where a 2-piece long front is unable to reach due to its limitations on articulation; in short, a 2-piece long front has more 'blind spots'. To access these 'blind spots', the machine has to be constantly moved and repositioned, whereas a 3-piece boom configuration reduces or even eliminates the need for frequent maneuvering of the machine, therefore improving the productivity and increasing fuel economy by a substantial margin.

Applications

- Ideal for river and sea dredging applications on either land or barge.
- Construction of breakwater structures, replacing typical practice where a crane is used.
- Heavy demolition work where a cutter or pulverizer can be attached.

Features

- Use of high strength steel for increased reliability.
- The design is simulated extensively, ensuring design integrity and to detect potential stress and fatigue points.
- Reduces the need for frequent maneuvering of the machine especially for breakwater work.





Mining

EIK-designed Super Long Reach can be found working in unison with the environment while safeguarding the natural surroundings

LONG REACH FRONT

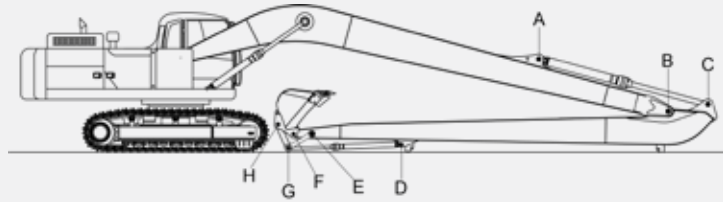
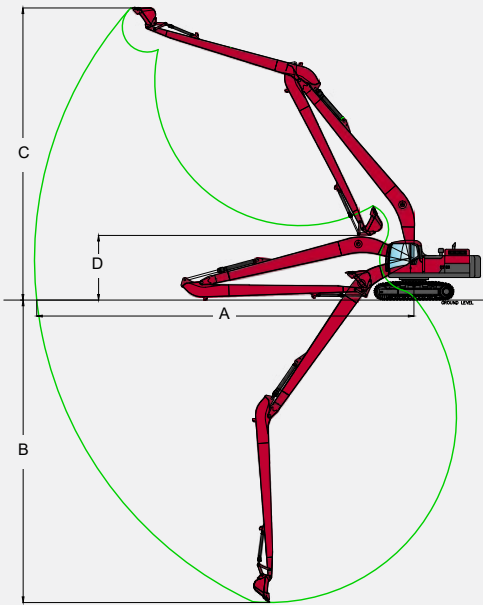

Each long reach package come standard with the following items:

- 1x boom
- 1x stick/dipper arm
- 1x bucket cylinder/ram
- Hydraulic lines for arm cylinder
- Hydraulic lines for bucket cylinder
- 1 set of linkage
- 1 x bucket
- Pins, refer to the side table

A	Arm/Stick Cylinder Head Pin	E	Arm Link Pin
B	Boom Front Pin	F	Bucket And Arm Link Pin
C	Arm/Stick Cylinder Rod Pin	G	Bucket Cylinder Rod Pin
D	Bucket Cylinder Head Pin	H	Bucket Link Pin

Excavator Operating Weight	Length		A Max. Reach		B Max. Reach		C Max. Reach		D Boom Height		Approximate Bucket Capacity	
	m	ft	m	ft	m	ft	m	ft	m	ft	m ³	Yard ³
6-8 ton (13,200 - 17,600 lb)	9.00	30'	9.00	30' 0"	4.65	15' 3"	8.60	28' 2"	2.20	7' 2"	0.25	0.33
11-14 ton (24,200 - 30,800 lb)	12.0	40'	11.90	39' 10"	7.90	25' 11"	12.35	40' 6"	2.30	7' 6"	0.35	0.46
15-17 ton (33,000 - 37,400 lb)	13.0	43'	13.00	43' 0"	9.10	29' 10"	11.85	38' 10"	2.45	8' 0"	0.40	0.52
18-22 ton (39,600 - 48,400 lb)	14.0 15.5 16.5	46' 50' 54'	14.00 15.40 16.50	46' 0" 50' 6" 54' 0"	10.10 11.15 12.45	33' 1" 36' 7" 40' 10"	13.00 13.70 17.70	42' 7" 44' 11" 58' 0"	2.65 2.65 2.70	8' 8" 8' 8" 8' 10"	0.50 0.40 0.40	0.65 0.52 0.52
23-26 ton (50,600 - 57,200 lb)	17.0 18.5	56' 60'	17.00 18.25	56' 0" 59' 10"	12.80 13.20	41' 11" 43' 3"	14.70 16.45	48' 2" 53' 11"	2.80 2.85	9' 2" 9' 4"	0.50 0.40	0.65 0.52
27 - 32 ton (59,400 - 70,400 lb)	18.5	60'	18.50	60' 0"	14.00	45' 11"	15.85	52' 0"	3.05	10' 00"	0.65	0.85
33 - 38 ton (72,600 - 83,600 lb)	18.5 20.0	60' 65'	18.50 20.00	60' 0" 65' 0"	13.90 15.30	54' 7" 50' 2"	16.15 17.05	52' 11" 55' 11"	3.15 3.40	10' 4" 11' 1"	0.70 0.65	0.91 0.85
40 - 45 ton (88,000 - 99,000 lb)	21.0 22.0	69' 72'	21.00 22.00	69' 0" 72' 0"	13.95 15.80	45' 9" 51' 10"	15.40 16.05	50' 6" 52' 7"	3.70 3.95	12' 1" 12' 11"	0.80 0.70	1.04 0.91
46 - 55 ton (101,200 - 121,000 lb)	21.0 22.0	69' 72'	21.00 22.00	69' 0" 72' 0"	15.80 16.70	51' 10" 54' 9"	17.10 17.65	56' 1" 57' 10"	3.55 3.80	11' 7" 12' 5"	0.90 0.80	1.17 1.04
60 - 68 ton (132,000 - 149,600 lb)	23.5	77'	23.50	77' 0"	17.00	55' 9"	19.95	65' 5"	3.95	12' 11"	1.50	1.95
70 - 78 ton (154,000 - 171,600 lb)	23.5 25.0	77' 82'	23.50 25.00	77' 0" 82' 0"	16.95 18.40	55' 7" 60' 4"	17.50 18.35	57' 4" 60' 2"	4.00 4.00	13' 1" 13' 1"	1.60 1.50	2.08 1.95
80 - 95 ton (176,000 - 209,000 lb)	23.5 25.00	77' 82'	23.50 25.00	77' 0" 82' 0"	17.35 18.65	56' 11" 61' 2"	19.95 20.95	65' 5" 68' 8"	4.25 4.35	13' 11" 14' 3"	1.60 1.50	2.08 1.95
100 - 125 ton (220,000 - 275,000 lb)	25.0 27.0	82' 88'	25.00 27.00	82' 0" 88' 0"	17.60 20.40	57' 8" 66' 11"	21.00 18.80	68' 10" 61' 8"	5.35 5.35	17' 6" 17' 6"	2.00 1.80	2.73 2.34

* The above specifications are for reference only, actual working range may vary from machine models.

** For the benefit of continuous product improvement, specifications are subjected to change without prior notice.

*** Different bucket design will affect the working envelop.

3.0

HIGH REACH DEMOLITION FRONT

An ultra high reach demolition boom is a purpose-built attachment to elevate demolition tools for tearing down multi-storey buildings. The beauty of the demolition boom is its ease of positioning and flexibility in maneuvering of tools in carrying out primary and secondary demolition jobs safely. EIK attachments are engineered for performance, reliability and low total cost of ownership in mind. As we fully understand the harsh working conditions, hence only quality steel is used in the fabrication. Demolition booms for excavators greater than 120 metric tons (264,000 lbs) will have a detachable and modular main boom with a quick coupling joint for efficient mounting and dismantling, as well as ease of ground handling and transportation.

With the greater emphasis on work environment safety and stricter regulation in the industry, high reach demolition booms are fast becoming the choice of attachment for demolishing old buildings, replacing the traditional and more accident prone practice where excavators were lifted onto the building to carry out the highly risky tasks. The demolition boom has changed the entire concept of tearing down buildings, not only improving the overall safety standard, but also extending the working radius and reach of the front end attachment.

We design and customize demolition solutions for every make and model of hydraulic excavators, starting from 10 metric tons (22,000lbs) mini excavators and upward. Depending on your excavators size, the demolition boom can easily handle work tools ranging from 0.5 - 4 metric tons (1,100 - 8,800 lbs).

We do undertake entire turnkey solutions in which we convert your existing excavator to a full-fledged demolition equipment. The customized conversion is not restricted to the following:

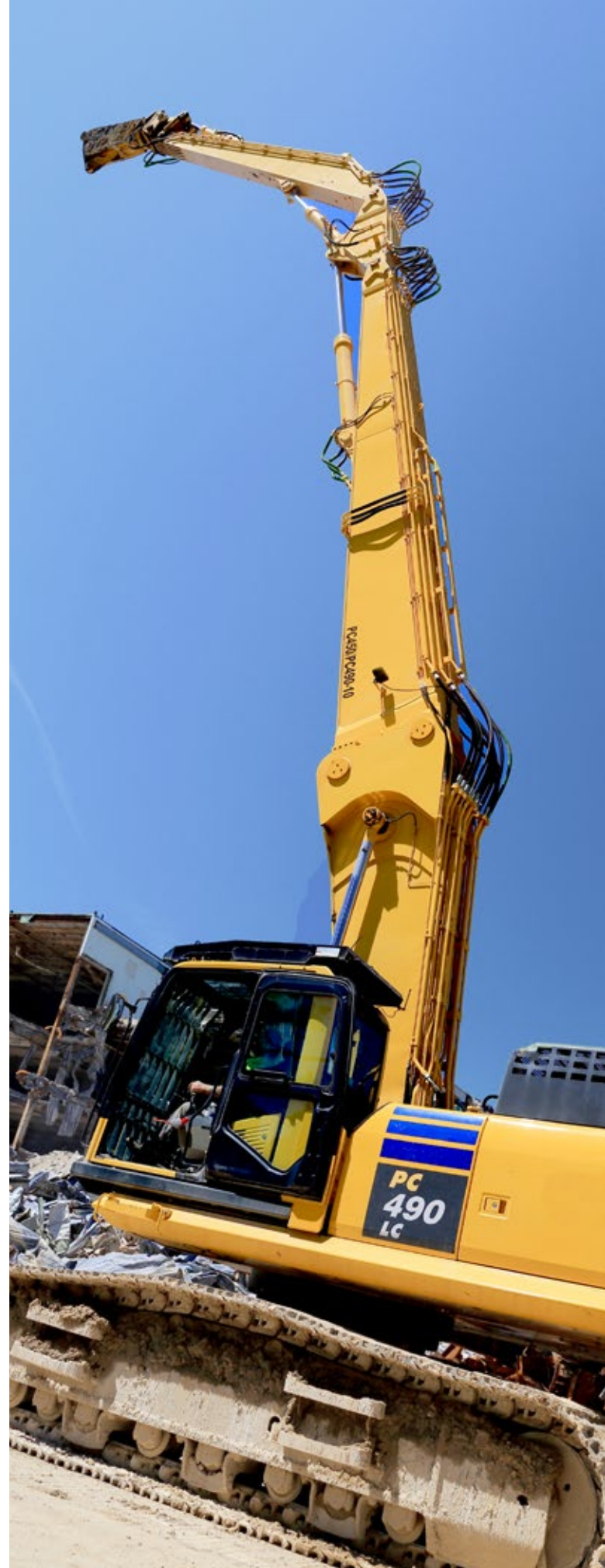

- Widening and lengthening of existing undercarriage.
- Addition of an extra hydraulic control system.
- Modification of cabin into articulating or tilting cabin.
- Cabin protection guard system.
- Integrated counterweight.
- Full commissioning of newly converted machine.

Applications

- Demolishing high-rise buildings and structures.
- Typically attached to a hydraulic breaker, multi-processor or hydraulic shear.

Features

- Use of high strength steel for increased reliability.
- Design is simulated extensively, ensuring design integrity and detecting potential stress and fatigue points.
- Hydraulic operated modular joint on main boom, ease of detaching for transportation.
- Cylinders installed with load hold safety valves.



4.0 MATERIAL HANDLING

Our goal in designing highly efficient material handling solutions is to help our customers “Scale New Heights in Productivity” in handling bulk materials. The machine is designed from ground up, transforming from a standard excavator into a piece of highly sophisticated equipment. The most attractive proposition of an excavator-based machine is its fully hydraulic control, which is undisputedly more efficient, easier to operate and less costly to operate and maintain than any traditional cranebased material handling machine.

The track crawler undercarriage is widened and lengthened to create a larger footprint. This modification ensures that the foundation is both rock solid and safe for the upper structure. Coupled with the swift motion of an articulating operator cabin mounted on an elevated platform, it offers the operator an unobstructed aerial visibility. This highly customized machine delivers the ultimate efficiency and flexibility for handling break bulk, dry bulk, general cargo and dock side, material handling at scrap yard, etc, achieving higher production throughput and long term cost saving.

Applications

- High volume bulk material handling.
- Ideal for loading and unloading bulk cargo at docks.
- Replaces cable operated material handling machines.

Features

- Widened and lengthened crawler track for stability.
- Elevated structure with safety platform and hand rail.
- Articulating operator cabin for excellent aerial visibility.
- Long reach front for maximum accessibility.



5.0

HEAVY DUTY GRAPPLE

The GP series heavy duty grapple is a reinforced box, 2-tine clamp over 3-tine frame design, ideal for rough, tough and general utility applications. This is a front end attachment designed for excavators to facilitate various applications, particularly ideal for rock handling, log grabbing, land clearing, stacking, piling, scrap handling, where applications require maximum clamping and prying force.

The lugs' design work perfectly with or without a quick coupler. Grapple is fully constructed from high tensile steel with internal reinforced structure, the tines are braced with Hardox wear-resistant steel for extra durability, reducing the frequency of costly downtime for maintenance. The curvature of the tines can be customized to suit different applications where objects and trash can vary widely in terms of shapes and sizes. The GP grapple has proven itself in various tough environments and applications.

Available in various models to suit excavator sizes ranging from 10 – 80 metric tons (22,000 – 176,000 lbs) operating weight. The GP series grapple is popular among customers who demand the very best in tackling the toughest job at hand.



Applications

- Demolition, rock handling, stacking, piling, general utilities.
- Ideal for applications that requires maximum clamping force.
- Handling of waste material for recycling industry.

Features

- Ease of assembly, works perfectly with or without quick coupler.
- Reinforced box design.
- 2-tine clamp over 3-tine frame structure.
- Tines are braced with abrasion resistant steel
- Large surface area for maximum heaped capacity.

6.0

BUCKET

Mass production model of buckets are welded by the latest robotic welding machine. We supply a full range of buckets to suit excavators up to 200 metric tons (440,000 lbs) operating weight. Buckets are designed differently, either in the type of material used or the profile of the bucket to suit different applications for the best possible productivity, fuel economy and durability.

Though the use of premium material is a prerequisite of a good bucket, there is more to it. Our engineers have accumulated numerous data over the years, and coupled with their experience and technical know-how, we are capable of designing buckets for various applications, considering the material density, size of material, abrasiveness of material, the working environment, high/low impact application and etc. You can count on us to deliver quality buckets that meet your most demanding applications.



Heavy Duty Bucket

EIK HD Bucket is designed for hard working area with rock scattered soil. HD bucket for heavy excavating of dense clay and light rock. The wide bottom wear plate spreads friction evenly to make sure the bucket can last for longer period.

Rock Bucket

Rock bucket is built for tough rock, quarry or high abrasive work in rocky areas. It is ideally designed for handling shot rock and severe digging. Thicker bottom and heavy duty side wear plates grade AR400 enhanced performance and durability.

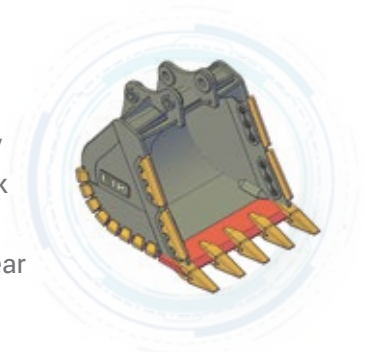



Applications

- Mining, rock handling, dredging, general purpose, ditching, trenching, etc.

Features

- Heavy duty design for harsh working environment.
- Light and durable for higher productivity and fuel economy.
- Use of both high strength and abrasion resistant steel for structural integrity and durability.

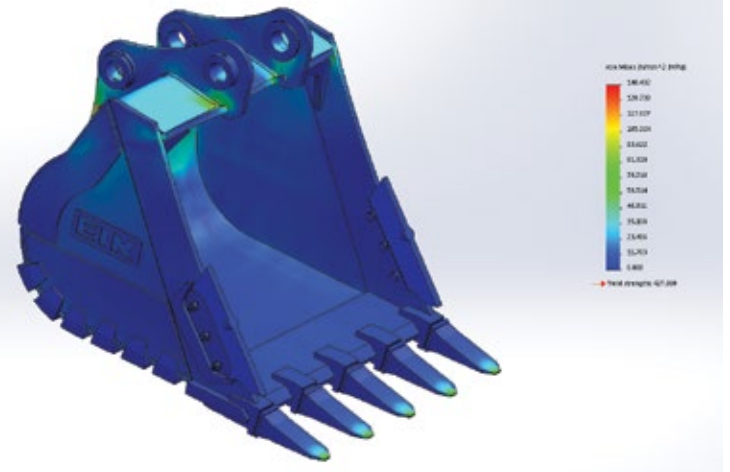

Skeleton Bucket

The EIK Skeleton Bucket used for sifting out rocks and digging in soil, effectively mining and sorting rock, and removing other debris without the soil. All the parts of the grille are individually welded to a reinforcing plate to guarantee the stability of the structure.

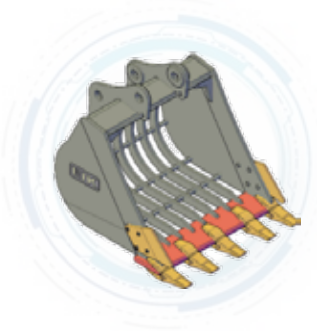

Wide Ditching Bucket

The Wide Ditching Bucket is designed for cleaning ditches, sloping, grading and other finish work. Wide and shallow design removes ditch sediment quickly.

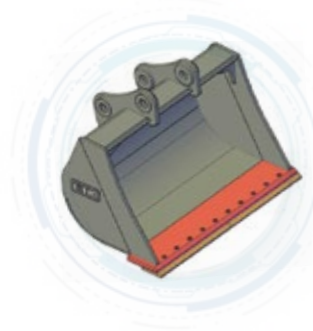

Ripper Bucket

The Ripper Bucket is suitable for extremely tough application. We designed the bucket with eminent abrasive resistant capability to ensure it is ideal for ripping, quarrying and hammering of rock. The extra thick bottom AR400 wear plates is used to increase wear life.



Narrow Bucket

The application is great for digging and trenching, especially when laying pipe or wiring. The narrow bucket is made from high quality steel so that to dig those deep trenches despite rocks and branches that may get in the way effectively.

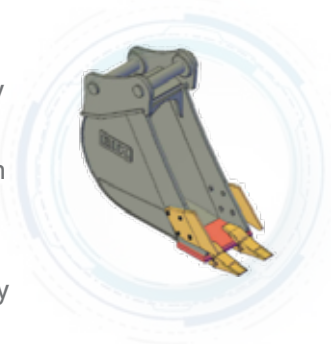

EIK PROVIDE SOLUTIONS FOR YOUR BUSINESS



Mining

Basic planning for mining operations will include where, when and what methods are to be used to excavate the natural deposit will include the use of reliable heavy machineries with robust attachments under the harshest environment.



Marine Dredging

Marine dredging carries the responsibility of cleaning and maintaining the natural waterways. Super Long Front with attachments like orange peel grab, buckets, will clear the bed of underwater by scooping all waste in shallow waters which will assist coastal protection, land reclamation and coastal redevelopment.



Breakwater

The breakwater structure constructed for the purpose of forming an artificial harbour with a basin so protected from the effect of waves as is to provide safe berthing for fishing vessels. The equipment is required to carry out the construction consists of a stable floating platform. EIK Super Long Front helps to reach the demanding slope and depth profile required



Winterland

Winter is associated with snow and freezing temperatures. During this time, road maintenance, winter constantly change and during winter, road maintenance become most important and the services involve a large number of operation. For contractors, it is utmost important to choose high quality and dependable attachments to maintain the roadworks during wintertime. With the quality track chain and track shoe, EIK AM series can work well during winter conditions.

Wetlands

EIK Marsh Buggy naturally excels in swampy and "difficult" conditions as it glides through with ease to help in maintaining its natural habitat.

Quarry

As one of the under-recognised contributor to modern day advancement, natural rocks from quarries are crushed and screened into rock aggregates for further processing with the help of EIK specially designed Rock Buckets.

Construction

In modern day construction, EIK specially designed High Reach Demolition Booms are highly sought after for its robustness and effectiveness and has contributed in the construction of new cities in the world.



EIK GROUP OF COMPANIES

EIK Engineering Sdn Bhd (HQ)

No. 10, Jalan SiLC 1/4,
Kawasan Perindustrian SiLC,
79200, Iskandar Puteri, Johor, Malaysia
Tel: +607 - 531 9922
Fax: +607 - 531 9919
Website : www.eikengineering.com
Email: sales@eikengineering.com.my
/ info@eikengineering.com

EIK Lam Engineering Sdn Bhd

24, Jalan Mega 1/4,
Taman Perindustrian Nusa Cemerlang,
79200 Nusajaya, Johor, Malaysia
Tel: +607 - 554 2700
Fax: +607 - 554 1785
Email: sales@eiklam.com.my

AMP Dredging Sdn Bhd

No 28, Jalan Astaka U8/84A,
Bukit Jelutong, 40150 Shah Alam, Selangor
Tel: +603 - 7859 9221
Fax: +603 - 7859 9231
Website : www.ampdredging.com
Email: ampoffice99@gmail.com

TCL Machinery (M) Sdn Bhd

No. 9, Jalan Tiong Emas 6,
Kawasan Perindustrian Tiong Nam,
81100 Johor Bahru, Johor, Malaysia.
Tel: +607 - 361 6546/ +607 - 364 8695
Fax : +607 - 364 8679
Website : www.tcl-machinery.com
Email: enquiry@tcl-machinery.com

REGIONAL SALES OFFICES

EIK International Corporation (United States)

14430 Grant Road, Cypress, Texas
77429 United States
Tel: +1 832-914-2646
Website : www.eikinternational.com
Email: info@eikinternational.com

EIK Engineering Sdn Bhd (Kuala Lumpur Branch)

No 28, Jalan Astaka U8/84A,
Bukit Jelutong, 40150 Shah Alam, Selangor
Tel: +603 - 7859 9221
Fax: +603 - 7859 9231
Email: sales_kl@eikengineering.com.my

EIK Engineering Pte. Ltd (Singapore)

135 Jurong Gateway Road, #03-315
Singapore 600135
Tel: +65 - 9815 9685
Email: sales@eikengineering.com
/ info@eikengineering.com

EIK Engineering Sdn Bhd (Sarawak Branch)

Lot 1176, Section 66
Kuching Town Land District
Jalan Utama, Pending Industrial Estate
93450 Kuching, Sarawak, Malaysia
Tel: +6082 - 335 922
Fax: +6082 - 345 922
Email: sales_sawarak@eikengineering.com.my



**EIK ENGINEERING,
YOUR SOLUTION PROVIDER**

EIK ENGINEERING SDN BHD

No. 10, Jalan SiLC 1/4, Kawasan Perindustrian SiLC,
79200 Iskandar Puteri, Johor, Malaysia.

E sales@eikengineering.com.my | info@eikengineering.com

www.eikengineering.com